

MSSC

QM2

High Resolution Inkjet Printer

Operation Guide



QM2-101



QM2-111



Table of Contents

Introduction.....	2
Dimensions and Specifications.....	2
Installation.....	3
Key Layout.....	5
Startup.....	6
Operation.....	7
Settings.....	7
Menu Language	7
Setting Date and Time	7
Setting Format for Date and Time Printing	7
Expiration Offset.....	8
Expiration Format	8
Setup Menu	9
Ink	9
Parameter	9
DT Tune.....	10
Total Count	10
Init Data	10
Extend	10
Serial Numbers.....	11
Editing and Selecting Messages.....	12
Editing/Creating Messages	12
Inputting Special Message Functions	12
Inputting Chinese Characters (Available in English menus only).....	13
Creating or Editing 2 Line Text.....	13
Selecting Message to Print.....	13
Maintenance.....	14
Installing Ink Cartridges	14
Cleaning the Print Head.....	14
Adjusting Screen Contrast	15
HP Bulk Ink System Setup	16
Appendix.....	21
Feet/min. to meters/min Conversion Table.....	21
Date and Hour Code Table	21
Key Assignments for Characters	22
Adjusting the Photo Eye	23
Sample Message Instructions.....	23
Accessories and Parts.....	24

Introduction

Congratulations on the purchase of your new MSSC QM2 Industrial Inkjet Printer from MSSC, LLC. We are confident you will be very pleased with the operation and performance of this durable, quality built machine for many years to come.

The QM2 Industrial Inkjet Printer operating manual provides the necessary information about the installation, operation, maintenance, and repair of your new inkjet printer.

Dimensions and Specifications

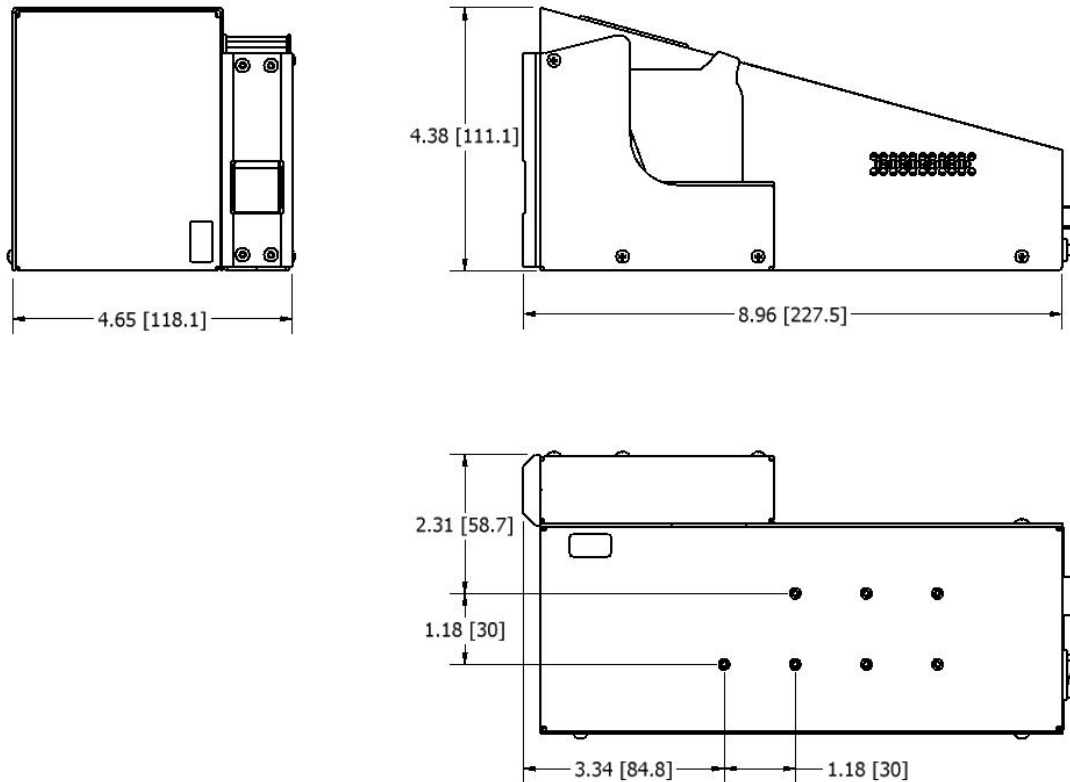

- All in one compact inkjet printer powered by HP Thermal Inkjet Technology
- Back-lit monochrome LCD screen
- Phone like keypad layout
- Menus in English, German, French, Spanish, Italian, and Japanese languages
- READY/ALARM indicator
- Prints at max. conveyor speed of 200 ft/min (60 m/min)
- 100 message memory w/ 30 full height characters max per message. More with 2 line text.
- Optimum 1/8" (3 mm) distance between print head and surface, not to exceed 1/4" (7 mm)
- Operates on 85-240V AC power source
- 40-105°F (5-40°C) Temperature, 10-80% Humidity

Installation

1. Select the mounting location.

Select a mounting location where there are guide bars on the conveyor. This will keep the print head at the correct distance of $1/8''$ (**3mm**) from the product preventing damage to the QM2. **CAUTION:** Avoid contact between the QM2 and the product as print quality may suffer.

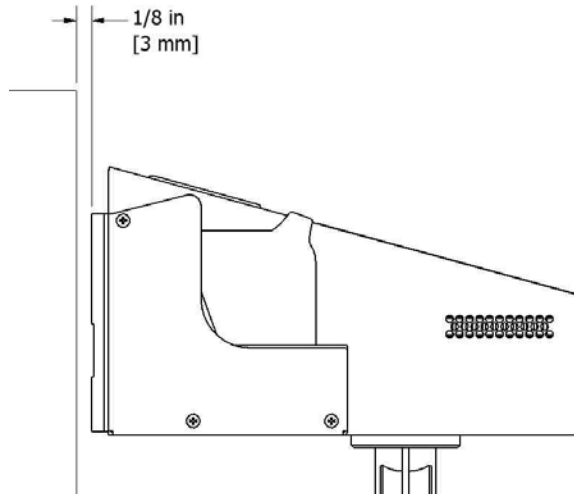

2. Mount the base clamp to the conveyor or floor.

Mount the QM2 to a solid structure such as a conveyor side rail. For floor mounting, secure the base clamp to the floor using concrete anchors. Use standard 18 mm tubing. Support the unit to prevent the print head from swaying or vibrating.

NOTE: the conveyor side rails should be $1/8''$ x 2.5'' or greater steel.

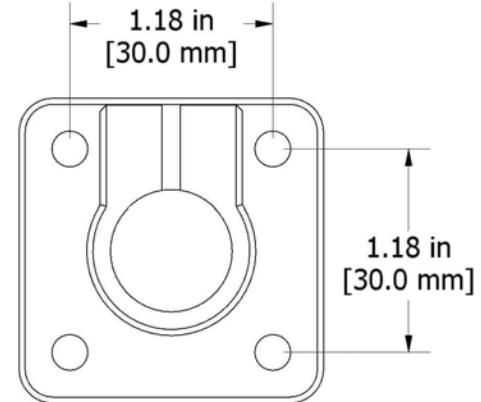

3. Assemble the bracketry to the base clamp.

Make sure the bracket is mounted securely. You want to avoid sway and vibration in the print head. This will greatly affect print quality.

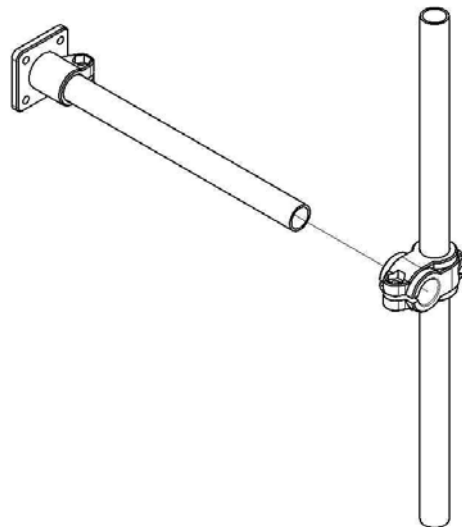

4. Mount the QM2 to the bracketry.

- Place the base clamp on the bottom of the QM2 over the end of the vertical tubing and tighten to secure the print head.
- Adjust the print head by loosening the cross clamp with a 5/32" or 4 mm allen wrench.
- The QM2 should be perpendicular to the product. If the print head is angled print quality will suffer.
- Once the QM2 is in position tighten all screws on the clamps

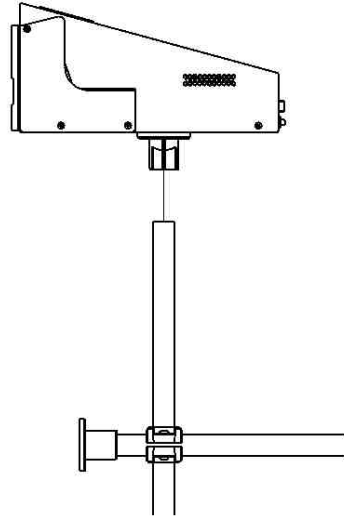
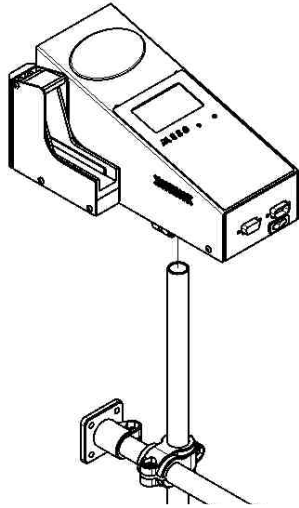

5. Install a QM2 print cartridge.

Power must be off to install and remove the print cartridge.

Please insert cartridge in horizontal direction to avoid damage to contacts. For more detailed instructions refer to pg. 14 of the QM2 Operation Guide.

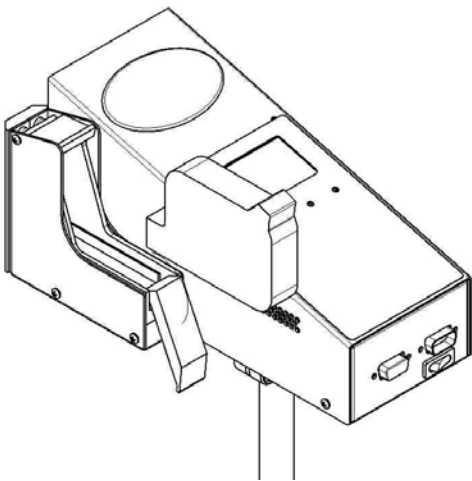

6. Plug in the QM2.

Plug the power cord into an appropriate voltage power source. **NOTE:** Be sure the power source for the QM2 is free from surges and spikes. Like other computer equipment, the QM2 is sensitive to surges and spikes. For best results, use a dedicated receptacle on a direct line from the power panel.

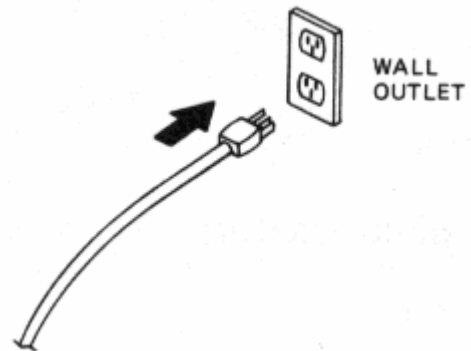

Key Layout

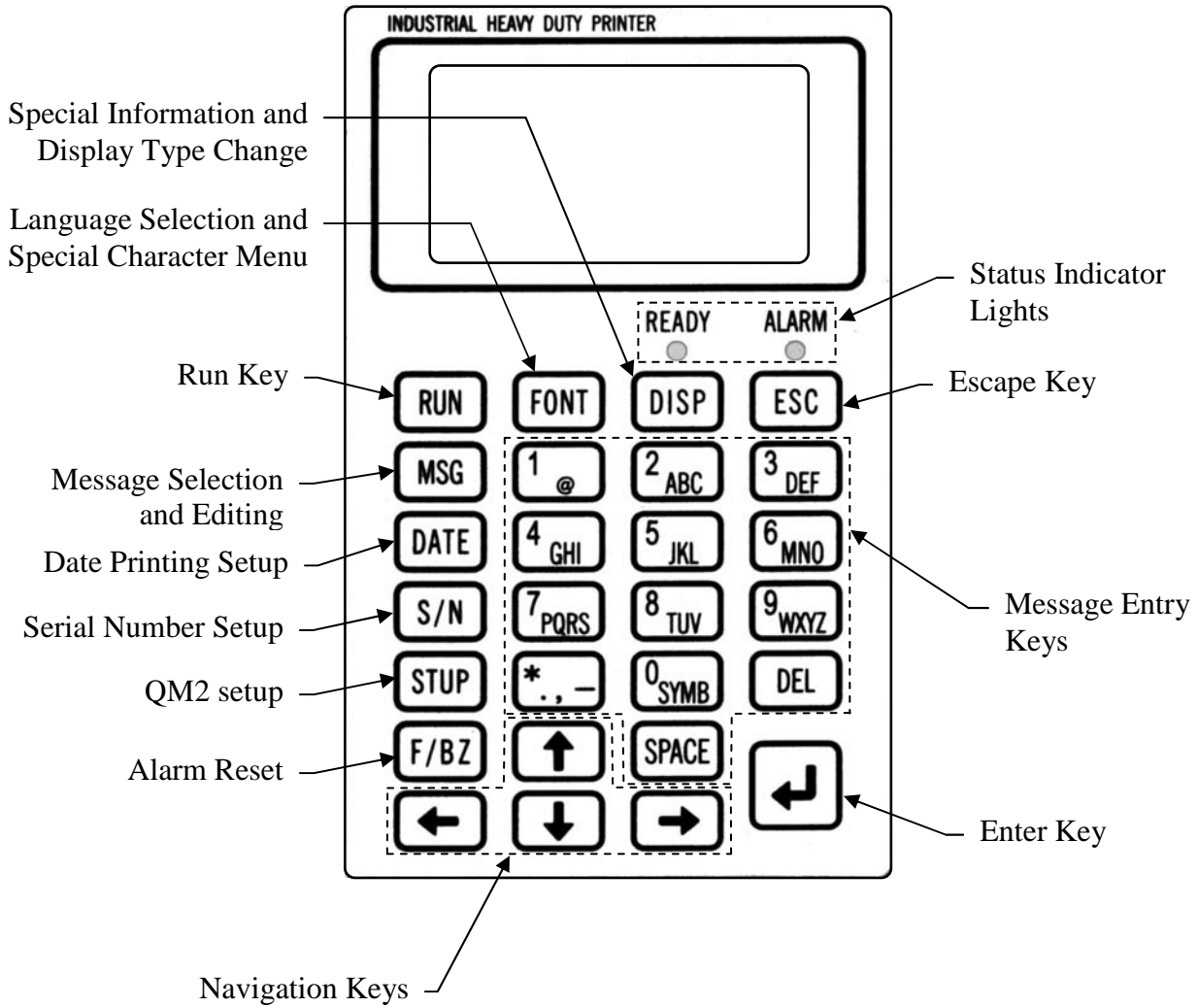

Startup

1. Install your QM2 and QM2 ink cartridge according to the installation instructions
 - a. **CAUTION: Power must be off when installing or replacing a QM2 Ink Cartridge.**
 - b. **CAUTION: The QM2 will only function with QM2 Ink Cartridges.**
2. Plug QM2 into proper power receptacle and turn the QM2 on using the on/off switch.
3. The QM2 can display screen prompts in English, French, Spanish, German and Japanese. The unit is shipped with English as the default language. To switch the language press the **FONT** key on the keypad, then using the arrow keys on the keypad select the desired language and then press the enter key. You can only change the language at the main menu screen. The QM2 will always restart in the last language selected.
4. Set the date and time using the **DATE** key on the keypad. Likewise, you will need to set the date and time format in order to print date and time. The format is set using the **DATE** key.
5. Enter your message(s) using the **MSG** key on the keypad and then using the arrow keys highlight **EDIT** and press enter key. You can load 100 messages, 00 – 99, and the maximum is 30 full height characters per message. To create a message or edit a message use the mobile phone like keypad layout.
6. To print the desired message, press **MSG**, then **SELECT** and press the enter key. Using the arrow keys, highlight the desired message and press the enter key. Press the enter key again indicating yes I want to print the message.
7. Last step before printing, you must setup the QM2. This is done using the **STUP** key on the keypad. There are many functions performed at this point.
 - a. **INK** allows you to set the start ink volume (new cartridge 42 ml), indicates ink volume status and you set the point where the low ink alarm LED lights.
 - b. **PARAMETER**, the most commonly used key, you set the **print delay** in millimeters (000 – 999), **character width** in millimeters (02-26), **character height** in millimeters (05-13), dot **density** (1-8), **Font** (2 to choose from), **print direction** as viewed from behind the printer, and the **line speed** in meters/minute must be entered by user. The width, density and speed are interrelated. If the settings are not acceptable the QM2 will not allow you to leave this window. The QM2 indicates which of these three values are to high or low using arrows to the left of the variable. Use the arrow keys to maneuver and change the values and the enter key to store changes.
 - c. **DT TUNE**, contains additional date formatting options.
 - d. **TOTAL CNT**, allows you to reset the total count (photocell trips)
 - e. **INIT DATA**, clears the memory of the entire unit.

CAUTION: If you do this you will lose all messages programmed and print parameter settings.
 - f. **EXTEND**, allows repeat printing of the selected message, count the number of dots in selected message, select the nozzle setting (firing half the 600 channels = **ODD**, **EVEN** or **AUTO** or fire all 600 channels = **BOTH**), **RS485** not used, **DRV PULSE** not used, **SENSR DELAY** set in millimeters, **GAP 2L** adjusts spacing between lines on 2 line special message. Use the arrow keys to navigate and enter key to store changes.

Operation

NOTE: Pressing the **RUN** key from any menu will return you to the main screen. However any unsaved changes will be lost.

Settings

Menu Language

1. From main screen press the **FONT** key.
2. Use the \uparrow and \downarrow keys to select desired language.
3. Press \downarrow to select and return to the main screen.

Setting Date and Time

The QM2 will retain current date and time once set, like any other computer device.

1. From the main screen press the **DATE** key.
2. Using the arrow keys select **TODAY** and press \downarrow .
3. Select **SET CLOCK** and press \downarrow .
4. Use the \uparrow and \downarrow keys to change highlighted field, use \leftarrow and \rightarrow keys to select the desired field.
5. When done press \downarrow to save changes and return to the previous menu.

Setting Format for Date and Time Printing

In order to print current date and time in a message, the date format must be entered using the special date characters found by pressing the **FONT** key. A brief explanation of these characters can be found in the table below. Once the date and time are set and the format is created, the current date and time can be printed by selecting the \boxed{P} character explained later.

1. From the main screen press the **DATE** key.
2. Using the arrow keys select **TODAY** and press \downarrow .
3. Select **FORMAT** and press \downarrow .

Enter the date in the desired format using the special date characters shown in the table below. These characters can be found by pressing the **FONT** key.

4. When finished press \downarrow select **YES** to save and press \downarrow again.

$\boxed{Y1}$	Inserts the first digit of a 2 digit year format. 07-20- <u>0</u> 7
$\boxed{Y2}$	Inserts the second digit of a 2 digit year format. 07-20-0 <u>7</u>
$\boxed{M1}$	Inserts the first digit of a 2 digit month format. <u>0</u> 7-20-07
$\boxed{M2}$	Inserts the second digit of a 2 digit month format. 0 <u>7</u> -20-07
\boxed{MX}	Inserts month number or abbreviation depending on settings in DT TUNE . <u>07</u> -20-07 or <u>JUL</u> -20-07
$\boxed{D1}$	Inserts the first digit of a 2 digit day format. 07- <u>2</u> 0-07

D 2	Inserts the second digit of a 2 digit day format. 07- <u>2</u> 0-07
D X	Inserts a 1 character date code. (See date and hour code table in the appendix) 07- <u>K</u> -07
H 1	Inserts the first digit of a 2 digit hour in 24 hour format. <u>1</u> 4:53
H 2	Inserts the second digit of a 2 digit hour in 24 hour format. 1 <u>4</u> :53
H X	Inserts a 1 character hour code. (See date and hour code table in appendix) <u>E</u> :53
M 1	Inserts the first digit of a 2 digit minute. 14: <u>5</u> 3
M 2	Inserts the second digit of a 2 digit minute. 14:5 <u>3</u>
J D	Inserts a Julian date code ranging from 001 to 365 (366 for leap year)

Expiration Offset

1. From the main screen press the **DATE** key.
2. Using the arrow keys select **EXPIRE** and press ↵.
3. Select **OFFSET** and press ↵.
4. Use the ↑ and ↓ keys to change highlighted field, use ← and → keys to select the desired field.
Note: Expiration offset is unique to each individual message.
5. When done press ↵ to save changes and return to the previous menu.

Expiration Format

1. From the main screen press the **DATE** key.
2. Using the arrow keys select **EXPIRE** and press ↵.
3. Select **FORMAT** and press ↵.
4. Enter the date in the desired format using the special date characters shown in the previous table.
These characters can be found by pressing the **FONT** key.
5. When finished press ↵ select **YES** to save and press ↵ again.

Setup Menu

To access the setup menu press the **STUP** key.

Ink

This sub menu allows the user to specify the ink cartridge volume as well as when the QM2 generates a low ink alarm.

To set the ink volume:

1. Press **STUP** key
2. Select **INK** and press ↵.
3. Use the ↑ and ↓ keys to change highlighted field.
4. Type in the desired value, 42 ml for a new cartridge or 370 ml for the bulk ink system.
5. When done press ↵ to save the changes and return to the previous menu.

Parameter

The **PARAMETER** sub menu is used to setup how the QM2 prints the selected message. The settings in this menu can be unique to each message or set up as common parameters.

Note: When a parameter is changed from the common settings; an asterisk (*) will appear next to the message number. To revert back to the common settings return to the parameter submenu and press the asterisk (*) key. This will restore all parameters for the selected message to the settings under **COMMON**.

- **MSG**: Select the message number to alter. If **COMMON** is selected, the settings will apply to all messages that do not have a custom setting.
- **DELAY**: Sets the distance between when the photo eye is tripped and the start of printing. This value can be set from 0 to 999mm (0 to 39.3in). **NOTE: 25mm = 1in.**
- **WIDTH**: Sets the width of the characters printed. This value can be set from 2 to 26mm (0.08 to 1.02in). The range of acceptable values is dependent on the **SPEED** and **DENSITY** settings.
- **HEIGHT**: Sets the height of the characters printed. This value can be set from 5 to 13 mm (0.2 to 0.51in).
- **DENSITY**: Controls the amount of ink deposited. A lower value means less ink and a lighter print. A higher value means more ink and a darker mark. The range of acceptable values is 1 to 8 dependent on the **SPEED** and **WIDTH** settings.
- **FONT**: Sets the font used in the message. There are two different fonts shown below.
- **DIRECT**: Sets the direction of conveyor travel as well as mark orientation.
- **SPEED**: Sets the QM2 for the speed the conveyor runs at. This value can be set from 1 to 60m/min (3 to 200ft/min).

Font 1 Font 2

Common Parameters set at Factory

MSG = COMMON
 DELAY = 000 mm
 WIDTH = 08 mm
 HEIGHT = 13 mm
 DENSITY = 4
 FONT = FONT 2
 DIRECT = ←ABC
 SPEED = 30.5 m/min

DT Tune

The **DT Tune** sub menu is where adjustments to date code formatting are made. The settings in this menu apply to all messages printing dates.

- **MX SIZE:** Sets the number of characters in month code. For a value of 2, a two digit number corresponding to the month is printed. For a value of 3, the three letter abbreviation for the month is printed
- **DT TRIM:** Sets how month and day characters with leading zeros are printed. There are three options
 - 2007.01.01: Prints leading zeros in day and month.
 - 2007. 1. 1: Replaces leading zeros with spaces as place holders.
 - 2007.1.1: Prints month and day with no leading zero or space.

DT TRIM is not available when MX SIZE is set to 3.

Total Count

Total count shows how many times the photo eye has triggered printing since the last time the count was reset. The count can be reset here by selecting **YES** and pressing ↵.

Init Data

The **INIT DATA** function **ERASES ALL DATA** except **TOTAL COUNT** and **S/N**. Once this is done any lost data cannot be recovered.

To initialize all data:

1. Press **STUP** key
2. Select **INIT DATA** and press ↵.
3. Select Yes and press ↵.

Extend

The **EXTEND** sub menu contains advanced printing and setup functions that change the way the QM2 prints.

- **RPEAT JET:**
 - **REPEAT:** Sets the number of times the message is repeated. “CONTINUE” repeats the message while the photo eye is activated.
 - **INTERVAL:** Not used.
 - **S/N COUNT:** “COUNT” changes the serial number each time the message is printed. “HOLD” changes the serial number with each activation of the photo eye.

- CNT DOTS: Displays the number of dots in a message and the volume of ink needed for each printing.
- SEL NOZZL: This setting controls what channels are used to print.
 - **AUTO**: (Recommended) the QM2 selects the best nozzle configuration based on operating conditions. (300 DPI)
 - **EVEN**: Prints using the even channels. (300 DPI)
 - **ODD**: Prints using the odd channels. (300 DPI)
 - **BOTH**: Prints using both channels. (600 DPI)
- RS485: This submenu configures the QM2 communications. Parameters in this menu should only be adjusted under the advice of MSSC, LLC.
- DRV PULSE: This menu controls the print head operating parameters. Parameters in this menu should only be adjusted under the advice of MSSC, LLC.
- SENSR DELAY: This setting allows for an overall offset for printing. This setting offsets all messages in addition to the DELAY setting in the Parameter menu.
- GAP 2L: This setting changes the gap between lines on the $\left[\frac{2}{3} \right]$ special message function. The value can be set from 0 to 90%.

Serial Numbers

The serial number setup menu can be accessed from the main screen by pressing the **S/N** key. This menu allows for the adjustment of how serial numbers are printed.

- **NEXT S/N**: Sets the next serial number to be printed. To change, enter the new number using the keypad.
- **RESET**: Resets the NEXT S/N value to the value in INITIAL. To use, press ← or → key to select yes and press ↵.
- **LENGTH**: Sets the desired number of digits in the serial number. The maximum number of digits is 8.
- **INCREMENT**: Sets the amount the serial number increases by at each sequential change.
- **INITIAL**: sets the value that NEXT S/N is set to when RESET is used.
- **COUNT UP**: Sets the number of times a serial number is printed before advancing to the next number.
- **COUNTING**: Keeps track of how many times a repeated serial number has been printed. This value can be set to reflect the number actually printed.

NOTE: COUNTING is decreased by 1 when the serial number setup menu is accessed.

Editing and Selecting Messages

The QM2 has space for 100 different messages. To access the message menu press the **MSG** key.

Editing/Creating Messages

To create or edit a message:

1. From the main screen press the **MSG** key.
2. Select **EDIT** and press \downarrow .
3. Select the desired message number to create or modify and press \downarrow . A selection can be made using the \uparrow and \downarrow keys or by keying in the message number.

NOTE: The **DISP** key changes the message preview between a general preview to a detail view showing the contents of the upper and lower lines of a 2 line message.

4. Enter the desired message using the keypad. When finished press \downarrow .
5. Select Yes and press \downarrow to save changes.

Inputting Special Message Functions

During message creation or editing pressing the **FONT** key accesses the library of special text strings.

Use the arrow keys to select the desired function and press \downarrow to select and insert into the message.

D T	Inserts the current date as formatted in date setup
E X	Inserts the expiration date as formatted in expiration date setup
2 L	Inserts 2 lines of text.
N	Inserts a serial number as formatted
G	Inserts a preloaded graphic
2 S	Inserts 2 lines of text with adjustable line spacing
SP 4	Inserts the equivalent of 4 spaces
SP 5	Inserts the equivalent of 5 spaces
SP 10	Inserts the equivalent of 10 spaces
SP 15	Inserts the equivalent of 15 spaces

Inputting Chinese Characters (Available in English menus only)



During message creation pressing the **FONT** key twice accesses the library of 30 simplified Chinese characters for insertion into a message. Use the arrow keys to select the desired character press ↵ to select and insert into the message.

年	月	日	时	分	秒	有	效	期	间
包	装	批	号	此	前	最	佳	保	质
卫	生	产	字	检	合	格	食	用	品

30 simplified Chinese characters available for use in messages

Creating or Editing 2 Line Text

To create or edit 2 line text

1. If the  character is not already inserted in the message being edited, press the **FONT** key and select the  character and press ↵.
2. Select  icon in edit window and press **MSG**.
3. Select the line to edit and press ↵.
4. Enter desired text.
5. After editing press ↵ to return to the **SELECT LINE** menu.
6. If done editing the 2 lines select **SET** and press ↵ to return to main edit window.

Selecting Message to Print

To select the message to print:

1. From the main screen press the **MSG** key.
2. Highlight **SELECT** and press ↵.
3. Select the desired message number to print and press ↵. A selection can be made using the ↑ and ↓ keys or by keying in the message number.
NOTE: The **DISP** key changes the message preview between a general preview to a detail view showing the contents of the upper and lower lines of a 2 line message.
4. Select Yes and press ↵. The QM2 will return to the main screen.
5. The unit is ready to print as soon as the green ready light turns on. If **STOP** is displayed in the upper left corner, press the **RUN** key.

Maintenance

The QM2 was designed to be easy to maintain for the user. However there are a few precautions:

1. Always turn off the QM2 before installing or removing an ink cartridge.
2. Never disassemble the QM2. There are no user serviceable parts inside.
3. Never drop or spray the QM2 with water or any other liquid.

Installing Ink Cartridges

1. Power off the QM2.
2. Flip the blue locking lever down.
3. Remove old ink cartridge
4. Remove the tape on the front of the nozzle by pulling on the loose end on the bottom.
5. With blue locking lever in the downward position, insert the ink cartridge as horizontal as possible to avoid damaging the contacts inside the cartridge stall.
6. With the cartridge all the way in the stall, flip the blue locking lever up.
7. The unit may now be powered on.
6. After Startup press the **STUP** key
7. Select **INK** and press **↵**.
8. Use the **↑** and **↓** keys if necessary to select the prompt for Current Ink Volume.
9. Type in the volume of the ink cartridge (42 ml for standard cartridges, 370 ml for the bulk ink system).
8. When done press **↵** to save the changes and return to the previous menu.

Cleaning the Print Head

If streaks missing dots or other print quality issues occur the print head may need to be cleaned as follows:

1. Power off the QM2.
2. Remove the ink cartridge from the cartridge stall.
3. Moisten a Tex Wipe or similar lint free cloth with de-ionized water. Paper towels are not recommended due to their abrasiveness. The scratches caused by paper towels will cause print quality to suffer.
4. With the nozzle pointed down, wipe the nozzle with the moistened wipe in the direction shown in the figure below. Holding the cartridge in any other orientation could cause air to enter the nozzle, causing streaks in printing.



5. When finished wiping the nozzle, reinstall the print cartridge and test.

Adjusting Screen Contrast

If the screen is difficult to read the contrast may need to be adjusted.

1. Remove cap plug from right side of machine.
2. Using a small flat blade screwdriver, rotate the adjustment screw clockwise to lighten or counterclockwise to darken.
3. When finished, replace the cap plug.

HP Bulk Ink System Setup

Note: Never exceed 10 inches (254 mm) height difference between printer cartridge and reservoir.
Never hold reservoir above printer cartridge.

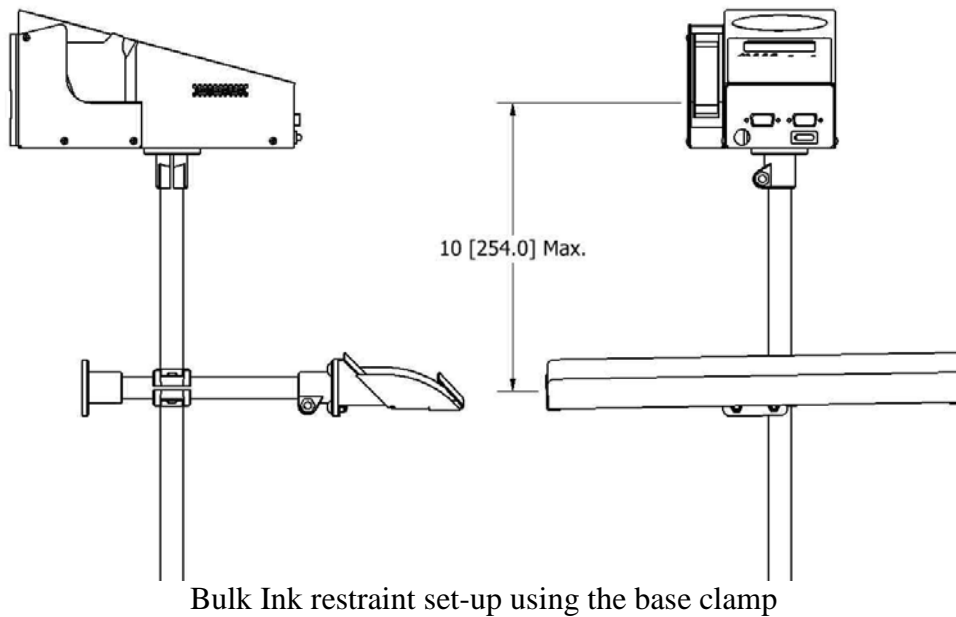
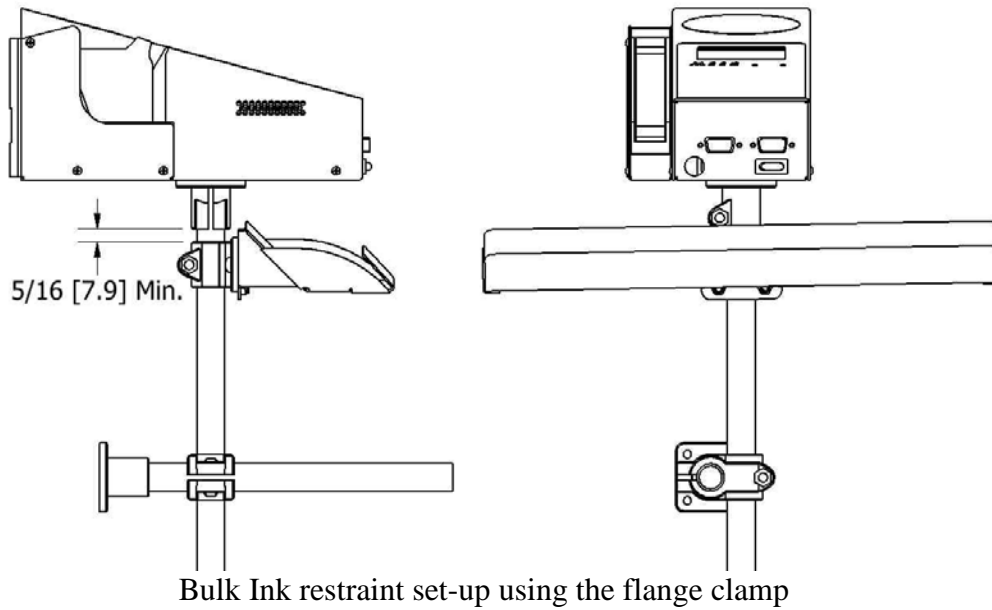

Ink system set up

1. Remove tape from the printhead.
2. Place printhead in the printer.
3. Place ink reservoir on the ink tray.
4. Ink tray must be located 4 inches below the printhead.
5. Insert valve into the plastic clip on printhead.
6. Listen for a click indicating the valve has snapped into place.

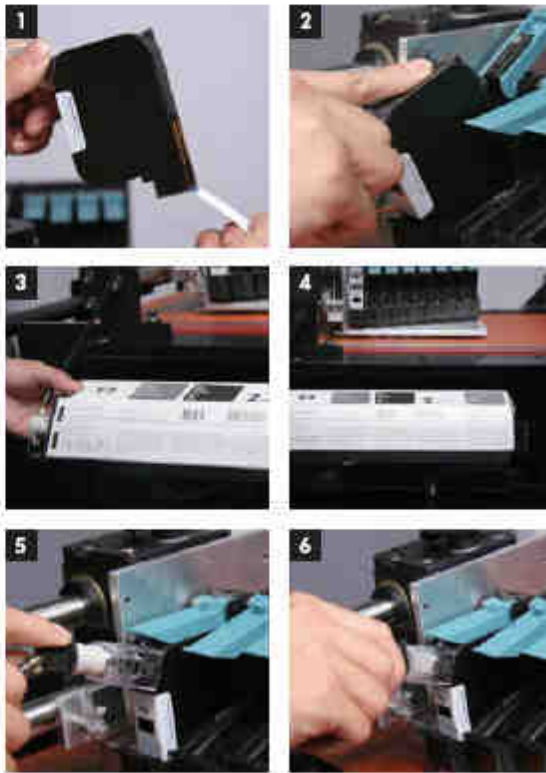

Important note

- Once the printhead is connected to the reservoir it cannot be taken apart without damaging the system.

Printhead removal

1. Grasp both sides of printhead to remove it from the printer stall.
2. Do not pull on the tube or clip.
3. Do not raise printhead more than 10 inches above the ink reservoir.



Important notes

- If printhead is raised higher than 10 inches above the ink reservoir, air will be drawn into it. This will damage the printhead.
- Do not position printhead below the ink reservoir to avoid ink leakage.

Printhead cleaning

- 1–2 Use a lint-free cloth, moistened with deionized water.
- 3–4 Wipe slowly and lightly across tip of the long edge with the printhead facing down as shown.

Important notes

- Do not use force or a dry cloth to avoid scratching the nozzles.
- Do not use a cloth with lint to avoid clogging the nozzles.

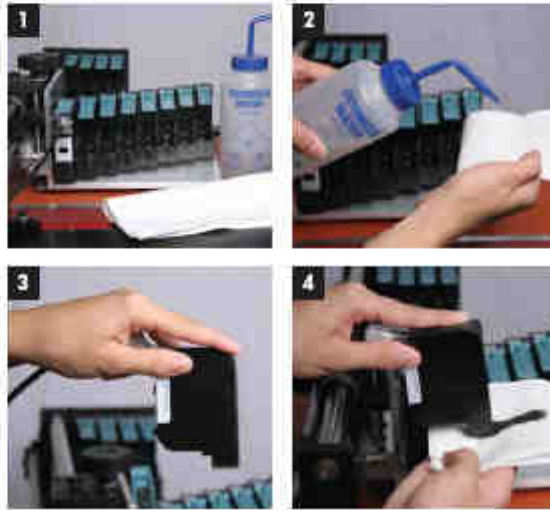

Does your printhead need cleaning?



This dirty printhead requires wiping.

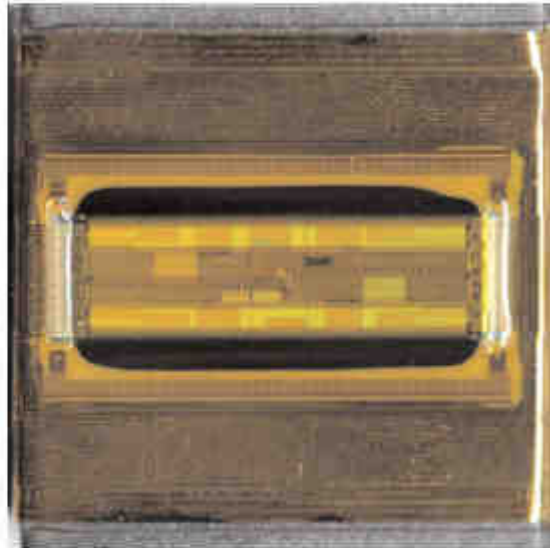

This is how your printhead should look after cleaning.

Purge the nozzles

If your printhead sits inactive for a period of time, you should purge the nozzles by following these steps.

- Wipe the printhead as shown in the Printhead Cleaning section above.
- Print a few lines of high-resolution text (600 dpi or higher).
- Higher resolutions exercise more nozzles and push out more ink.

Important note

- Do not shake the printhead as ink pressure will damage the nozzles.



Short- and long-term storage procedures

If stored for less than one day

- Leave printhead in the machine.
- Wipe and purge the printhead next time it is used.

If stored for more than one day

- Remove printhead from the printer stall.
- Place printhead above the ink reservoir and fasten with a rubber band as shown.
- Place the entire system in an airtight container with a damp cloth or sponge to prevent printhead from drying out.
- Close the container tightly.
- Wipe and purge the printhead next time it is used.



System disposal

- Keep printhead connected to the ink reservoir when disposing of system.
- Place the entire system in a plastic bag to avoid ink leakage.

Important handling cautions

- Never squeeze the ink reservoir as this will push ink out of the printhead.
- Never shake, drop or hit the printhead to avoid getting air in it.
- Never hold the printhead more than 10 inches above the ink reservoir when removing the system for storage to avoid getting air in it.
- Never hold printhead below the reservoir to avoid ink leakage.

Appendix

Feet/min. to meters/min Conversion Table

ft/min	m/min
5	1.5
10	3.0
15	4.6
20	6.1
25	7.6
30	9.1
35	10.7
40	12.2
45	13.7
50	15.2
55	16.8
60	18.3
65	19.8
70	21.3
75	22.9
80	24.4
85	25.9
90	27.4
95	29.0
100	30.5

ft/min	m/min
105	32.0
110	33.5
115	35.1
120	36.6
125	38.1
130	39.6
135	41.1
140	42.7
145	44.2
150	45.7
155	47.2
160	48.8
165	50.3
170	51.8
175	53.3
180	54.9
185	56.4
190	57.9
195	59.4
200	61.0

Date and Hour Code Table

Date	Code
1	1
2	2
3	3
4	4
5	5
6	6
7	7
8	8
9	9
10	A
11	B
12	C
13	D
14	E
15	F
16	G

Date	Code
17	H
18	I
19	J
20	K
21	L
22	M
23	N
24	O
25	P
26	Q
27	R
28	S
29	T
30	U
31	V

Distance conversion: 1 inch = 25.4 mm

Key Assignments for Characters

1 ●	1 @
2 ABC	A B C 2 a b c
3 DEF	D E F 3 d e f
4 GHI	G H I 4 g h i
5 JKL	J K L 5 j k l
6 MNO	English Language M N O 6 m n o
	Spanish language M Ñ O 6 m ñ o
7 PQRS	P Q R S 7 p q r s
8 TUV	T U V 8 t u v
9 WXYZ	W X Y Z 9 w x y z
* ., -	* . , - / + = : ' () #
0 SYMB	0 ! \$ % & [] □ ■

Adjusting the Photo Eye

In some instances, adjustment of the photo eye may be necessary to improve the performance of the QM2. The photo eye on the QM2 has an adjustment dial and indicator lights on the bottom to aid in adjustment. The green light indicates that the sensor is receiving power. The red light comes on whenever the sensor is tripped.

Sample Message Instructions

2 LINE 1st
2nd

Follow the directions below to enter the above sample message.

NOTE: to save space in the manual single key strokes are shown. It will be necessary to press a single key multiple times to arrive at the desired character.

1. From the main screen press the **MSG** key.
2. Select **EDIT** and press ↵.
3. Select the desired message number to modify and press ↵. A selection can be made using the ↑ and ↓ keys or by keying in the message number.

NOTE: The **DISP** key changes the message preview between a general preview to a detail view showing the contents of the upper and lower lines of a 2 line message.

4. If there is any text in the current message window, use the DEL key to remove it.
5. Enter the message above using the following keys:

2 ABC SPACE 5 JKL 4 GHI 6 MNO 3 DEF SPACE

Then press the **FONT** Key and use the arrow keys to select the  font character and press ↵.

With the  character selected press the **MSG** key.

Use the arrow keys to select **UPP** and press ↵.

Enter the upper line of the 2 line message using the following keys:

1 @ 7 PQRS 8 TUV and press ↵.

Use the arrow keys to select **LOW** and press ↵.

Enter the lower line of the 2 line message using the following keys:

2 ABC 6 MNO 3 DEF and press ↵.

Use the arrow keys to select **SET** and press ↵ to return to the main message editing screen.

6. Select Yes and press ↵ to save changes.

Accessories and Parts

Mounting Hardware

55325	Remote Print Head Mounting Kit
55335	Heavy Duty Mounting Clamps
55345	Heavy Duty Flange Clamp
55355	Heavy Duty Joint Clamp

Bulk Ink System

55955	Bulk Ink Restraint
55950	Bulk Ink System (370 cc); Standard Black

Ink Cartridges

55900	Ink Cartridge (42 cc); Standard Black
55901	Ink Cartridge (42 cc); Red
55902	Ink Cartridge (42 cc); Green
55903	Ink Cartridge (42 cc); Blue
55904	Ink Cartridge (42 cc); Yellow
55975	Ink Cartridge (42 cc); VB Premium Black
55350	Texwipe Lint-Free Cotton Cloths (25 per pack)